

## SkyLine ProS Natural Gas Combi Oven 5 trays, 400X600mm Bakery

ITEM # \_\_\_\_\_

MODEL # \_\_\_\_\_

NAME # \_\_\_\_\_

SIS # \_\_\_\_\_

AIA # \_\_\_\_\_

**227680 (ECOG61K2GB)**

SkyLine ProS Combi Boilerless Oven with touch screen control, 5 400x600mm, gas, 2 cooking modes (recipe program, manual), automatic cleaning, for bakery/pastry, pitch 80mm

### Short Form Specification

#### Item No.

- Combi oven with high resolution full touch screen interface, multilanguage.
- Boilerless steaming function to add and retain moisture.
  - OptiFlow air distribution system to achieve maximum performance with 7 fan speed levels.
  - SkyClean: Automatic and built-in self cleaning system. 5 automatic cycles (soft, medium, strong, extra strong, rinse-only) and green functions to save energy, water, detergent and rinse aid.
  - Cooking modes: Programs (a maximum of 1000 recipes can be stored and organized in 16 different categories); Manual; EcoDelta cooking cycle.
  - Special functions: MultiTimer cooking, Plan-n-Save to cut running costs, Make-it-Mine to customize interface, SkyHub to customize homepage, agenda MyPlanner, automatic backup mode to avoid downtime.
  - USB port to download HACCP data, programs and settings. Connectivity ready.
  - Single sensor core temperature probe.
  - Double-glass door with LED lights.
  - Stainless steel construction throughout.
  - Supplied with n.1 pastry tray rack 400x600 mm, 80 mm pitch.

### Main Features

- Boilerless steaming function to add and retain moisture for high quality, consistent cooking results.
- Dry hot convection cycle (max 300 °C) ideal for low humidity cooking. Automatic moistener (11 settings) for boiler-less steam generation.
- EcoDelta cooking: cooking with food probe maintaining preset temperature difference between the core of the food and the cooking chamber.
- Programs mode: a maximum of 1000 recipes can be stored in the oven's memory, to recreate the exact same recipe at any time. The recipes can be group in 16 different categories to better organize the menu. 16-step cooking programs also available.
- MultiTimer function to manage up to 20 different cooking cycles at the same time, improving flexibility and ensuring excellent cooking results. Can be saved up to 200 MultiTimer programs.
- Fan with 7 speed levels from 300 to 1500 RPM and reverse rotation for optimal evenness. Fan stops in less than 5 seconds when door is opened.
- Single sensor core temperature probe included.
- Pictures upload for full customization of cooking cycles.
- Automatic fast cool down and pre-heat function.
- Different chemical options available: solid (phosphate-free), liquid (requires optional accessory).
- GreaseOut: predisposed for integrated grease drain and collection for safer operation (dedicated base as optional accessory).
- USB port to download HACCP data, share cooking programs and configurations. USB port also allows to plug-in sous-vide probe (optional accessory).
- Back-up mode with self-diagnosis is automatically activated if a failure occurs to avoid downtime.
- Capacity: 5 400x600mm trays.
- OptiFlow air distribution system to achieve maximum performance in chilling/heating evenness and temperature control thanks to a special design of the chamber.

### Construction

- Double thermo-glazed door with open frame construction, for cool outside door panel. Swing hinged easy-release inner glass on door for easy cleaning.
- Seamless hygienic internal chamber with all rounded corners for easy cleaning.
- 304 AISI stainless steel construction throughout.
- Front access to control board for easy service.
- IPX 5 spray water protection certification for easy cleaning.
- Supplied with n.1 pastry tray rack 400x600 mm, 80 mm pitch.

### User Interface & Data Management

- High resolution full touch screen interface (translated in more than 30 languages) - color-blind friendly panel.
- Make-it-mine feature to allow full personalization

APPROVAL: \_\_\_\_\_

or locking of the user interface.

- SkyHub lets the user group the favorite functions in the homepage for immediate access.
- MyPlanner works as an agenda where the user can plan the daily work and receive personalized alerts for each task.
- Connectivity ready for real time access to connected appliances from remote and HACCP monitoring (requires optional accessory).
- Trainings and guidances supporting materials easily accessible by scanning QR-Code with any mobile device.
- Automatic consumption visualization at the end of the cycle.
- Connectivity ready for real time access to connected appliances from remote and data monitoring (requires optional accessory – contact the Company for more details).

### Sustainability

- Human centered design with 4-star certification for ergonomics and usability.
- Wing-shaped handle with ergonomic design and hands-free opening with the elbow, making managing trays simpler. Protected by registered design (EM003143551 and related family).
- Reduced powerfunction for customized slow cooking cycles.
- SkyClean: Automatic and built-in self cleaning system. 5 automatic cycles (soft, medium, strong, extra strong, rinse-only) and green functions to save energy, water, detergent and rinse aid. Also programmable with delayed start.
- Plan-n-Save function organizes the cooking sequence of the chosen cycles optimizing the work in the kitchen from a time and energy efficiency point of view.

### Included Accessories

- 1 of Bakery/pastry rack kit for 6 GN 1/1 oven with 5 racks 400x600mm and 80mm pitch PNC 922655

### Optional Accessories

- Water softener with cartridge and flow meter (high steam usage) PNC 920003
- Water filter with cartridge and flow meter for 6 & 10 GN 1/1 ovens (low-medium steam usage - less than 2hrs per day full steam) PNC 920004
- Water softener with salt for ovens with automatic regeneration of resin PNC 921305
- Wheel kit for 6 & 10 GN 1/1 and 2/1 GN oven base (not for the disassembled one) PNC 922003
- Pair of AISI 304 stainless steel grids, GN 1/1 PNC 922017
- Pair of grids for whole chicken (8 per grid - 1,2kg each), GN 1/1 PNC 922036
- AISI 304 stainless steel grid, GN 1/1 PNC 922062
- Grid for whole chicken (4 per grid - 1,2kg each), GN 1/2 PNC 922086
- External side spray unit (needs to be mounted outside and includes support to be mounted on the oven) PNC 922171
- Baking tray for 5 baguettes in perforated aluminum with silicon coating, 400x600x38mm PNC 922189
- Baking tray with 4 edges in perforated aluminum, 400x600x20mm PNC 922190
- Baking tray with 4 edges in aluminum, 400x600x20mm PNC 922191

- Pair of frying baskets PNC 922239
- AISI 304 stainless steel bakery/pastry grid 400x600mm PNC 922264
- Double-step door opening kit PNC 922265
- Grid for whole chicken (8 per grid - 1,2kg each), GN 1/1 PNC 922266
- USB probe for sous-vide cooking PNC 922281
- Grease collection tray, GN 1/1, H=100 mm PNC 922321
- Kit universal skewer rack and 4 long skewers for Lengthwise ovens PNC 922324
- Universal skewer rack PNC 922326
- 4 long skewers PNC 922327
- Volcano Smoker for lengthwise and crosswise oven PNC 922338
- Multipurpose hook PNC 922348
- 4 flanged feet for 6 & 10 GN , 2", 100-130mm PNC 922351
- Grid for whole duck (8 per grid - 1,8kg each), GN 1/1 PNC 922362
- Tray support for 6 & 10 GN 1/1 disassembled open base PNC 922382
- Wall mounted detergent tank holder PNC 922386
- USB single point probe PNC 922390
- IoT module for OnE Connected and SkyDuo (one IoT board per appliance - to connect oven to blast chiller for Cook&Chill process). PNC 922421
- Tray rack with wheels, 6 GN 1/1, 65mm pitch PNC 922600
- Tray rack with wheels, 5 GN 1/1, 80mm pitch PNC 922606
- Bakery/pastry tray rack with wheels 400x600mm for 6 GN 1/1 oven and blast chiller freezer, 80mm pitch (5 runners) PNC 922607
- Slide-in rack with handle for 6 & 10 GN 1/1 oven PNC 922610
- Open base with tray support for 6 & 10 GN 1/1 oven PNC 922612
- Cupboard base with tray support for 6 & 10 GN 1/1 oven PNC 922614
- Hot cupboard base with tray support for 6 & 10 GN 1/1 oven holding GN 1/1 or 400x600mm trays PNC 922615
- External connection kit for liquid detergent and rinse aid PNC 922618
- Grease collection kit for GN 1/1-2/1 cupboard base (trolley with 2 tanks, open/close device for drain) PNC 922619
- Stacking kit for 6 GN 1/1 oven placed on gas 6 GN 1/1 oven PNC 922622
- Stacking kit for 6 GN 1/1 oven placed on gas 10 GN 1/1 oven PNC 922623
- Trolley for slide-in rack for 6 & 10 GN 1/1 oven and blast chiller freezer PNC 922626
- Trolley for mobile rack for 2 stacked 6 GN 1/1 ovens on riser PNC 922628
- Trolley for mobile rack for 6 GN 1/1 on 6 or 10 GN 1/1 ovens PNC 922630
- Riser on feet for 2 6 GN 1/1 ovens or a 6 GN 1/1 oven on base PNC 922632

• Riser on wheels for stacked 2x6 GN 1/1 ovens, height 250mm	PNC 922635	<input type="checkbox"/>	• Non-stick universal pan, GN 1/1, H=20mm	PNC 925000	<input type="checkbox"/>
• Stainless steel drain kit for 6 & 10 GN oven, dia=50mm	PNC 922636	<input type="checkbox"/>	• Non-stick universal pan, GN 1/1, H=40mm	PNC 925001	<input type="checkbox"/>
• Plastic drain kit for 6 & 10 GN oven, dia=50mm	PNC 922637	<input type="checkbox"/>	• Non-stick universal pan, GN 1/1, H=60mm	PNC 925002	<input type="checkbox"/>
• Grease collection kit for GN 1/1-2/1 open base (2 tanks, open/close device for drain)	PNC 922639	<input type="checkbox"/>	• Double-face griddle, one side ribbed and one side smooth, GN 1/1	PNC 925003	<input type="checkbox"/>
• Wall support for 6 GN 1/1 oven	PNC 922643	<input type="checkbox"/>	• Aluminum grill, GN 1/1	PNC 925004	<input type="checkbox"/>
• Dehydration tray, GN 1/1, H=20mm	PNC 922651	<input type="checkbox"/>	• Frying pan for 8 eggs, pancakes, hamburgers, GN 1/1	PNC 925005	<input type="checkbox"/>
• Flat dehydration tray, GN 1/1	PNC 922652	<input type="checkbox"/>	• Flat baking tray with 2 edges, GN 1/1	PNC 925006	<input type="checkbox"/>
• Open base for 6 & 10 GN 1/1 oven, disassembled - NO accessory can be fitted with the exception of 922382	PNC 922653	<input type="checkbox"/>	• Baking tray for 4 baguettes, GN 1/1	PNC 925007	<input type="checkbox"/>
• Bakery/pastry rack kit for 6 GN 1/1 oven with 5 racks 400x600mm and 80mm pitch	PNC 922655	<input type="checkbox"/>	• Potato baker for 28 potatoes, GN 1/1	PNC 925008	<input type="checkbox"/>
• Stacking kit for 6 GN 1/1 combi oven on 15&25kg blast chiller/freezer crosswise	PNC 922657	<input type="checkbox"/>	• Non-stick universal pan, GN 1/2, H=20mm	PNC 925009	<input type="checkbox"/>
• Heat shield for stacked ovens 6 GN 1/1 on 6 GN 1/1	PNC 922660	<input type="checkbox"/>	• Non-stick universal pan, GN 1/2, H=40mm	PNC 925010	<input type="checkbox"/>
• Heat shield for stacked ovens 6 GN 1/1 on 10 GN 1/1	PNC 922661	<input type="checkbox"/>	• Non-stick universal pan, GN 1/2, H=60mm	PNC 925011	<input type="checkbox"/>
• Heat shield for 6 GN 1/1 oven	PNC 922662	<input type="checkbox"/>	• Compatibility kit for installation on previous base GN 1/1	PNC 930217	<input type="checkbox"/>
• Kit to convert from natural gas to LPG	PNC 922670	<input type="checkbox"/>	<b>Recommended Detergents</b>		
• Kit to convert from LPG to natural gas	PNC 922671	<input type="checkbox"/>	• C25 Rinse & Descale tab 2in1 rinse aid and descaler in disposable tablets for Skyline ovens Professional 2in1 rinse aid and descaler in disposable tablets for new generation ovens with automatic washing system. Suitable for all types of water. Packaging: 1 drum of 50 30g tablets. each	PNC 0S2394	<input type="checkbox"/>
• Flue condenser for gas oven	PNC 922678	<input type="checkbox"/>	• C22 Cleaning Tab Disposable detergent tablets for SkyLine ovens Professional detergent for new generation ovens with automatic washing system. Suitable for all types of water. Packaging: 1 drum of 100 65g tablets. each	PNC 0S2395	<input type="checkbox"/>
• Fixed tray rack for 6 GN 1/1 and 400x600mm grids	PNC 922684	<input type="checkbox"/>			
• Kit to fix oven to the wall	PNC 922687	<input type="checkbox"/>			
• Tray support for 6 & 10 GN 1/1 oven base	PNC 922690	<input type="checkbox"/>			
• 4 adjustable feet with black cover for 6 & 10 GN ovens, 100-115mm	PNC 922693	<input type="checkbox"/>			
• Detergent tank holder for open base	PNC 922699	<input type="checkbox"/>			
• Bakery/pastry runners 400x600mm for 6 & 10 GN 1/1 oven base	PNC 922702	<input type="checkbox"/>			
• Wheels for stacked ovens	PNC 922704	<input type="checkbox"/>			
• Chimney adaptor needed in case of conversion of 6 GN 1/1 or 6 GN 2/1 ovens from natural gas to LPG	PNC 922706	<input type="checkbox"/>			
• Mesh grilling grid, GN 1/1	PNC 922713	<input type="checkbox"/>			
• Probe holder for liquids	PNC 922714	<input type="checkbox"/>			
• Exhaust hood with fan for 6 & 10 GN 1/1 ovens	PNC 922728	<input type="checkbox"/>			
• Exhaust hood with fan for stacking 6+6 or 6+10 GN 1/1 ovens	PNC 922732	<input type="checkbox"/>			
• Exhaust hood without fan for 6&10 1/1GN ovens	PNC 922733	<input type="checkbox"/>			
• Exhaust hood without fan for stacking 6+6 or 6+10 GN 1/1 ovens	PNC 922737	<input type="checkbox"/>			
• Fixed tray rack, 5 GN 1/1, 85mm pitch	PNC 922740	<input type="checkbox"/>			
• 4 high adjustable feet for 6 & 10 GN ovens, 230-290mm	PNC 922745	<input type="checkbox"/>			
• Tray for traditional static cooking, H=100mm	PNC 922746	<input type="checkbox"/>			
• Double-face griddle, one side ribbed and one side smooth, 400x600mm	PNC 922747	<input type="checkbox"/>			
• Trolley for grease collection kit	PNC 922752	<input type="checkbox"/>			
• Water inlet pressure reducer	PNC 922773	<input type="checkbox"/>			
• Extension for condensation tube, 37cm	PNC 922776	<input type="checkbox"/>			

Front

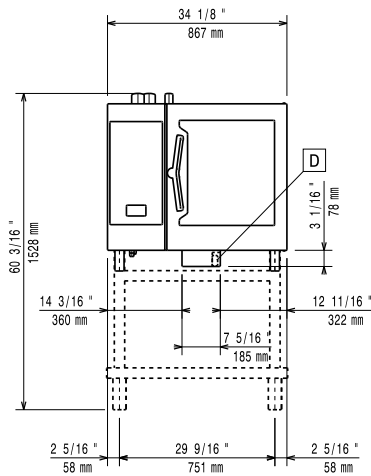

Side

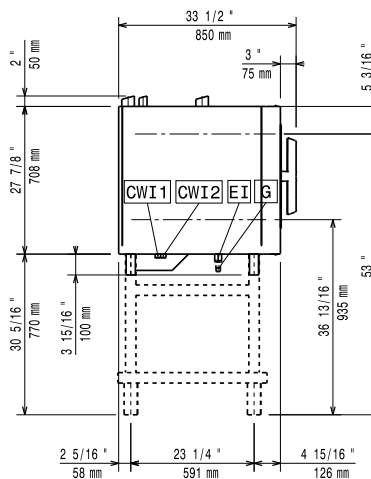

- CWI1 = Cold Water inlet 1 (cleaning)      EI = Electrical inlet (power)  
 CWI2 = Cold Water Inlet 2 (steam generator)      G = Gas connection  
 D = Drain  
 DO = Overflow drain pipe

Top

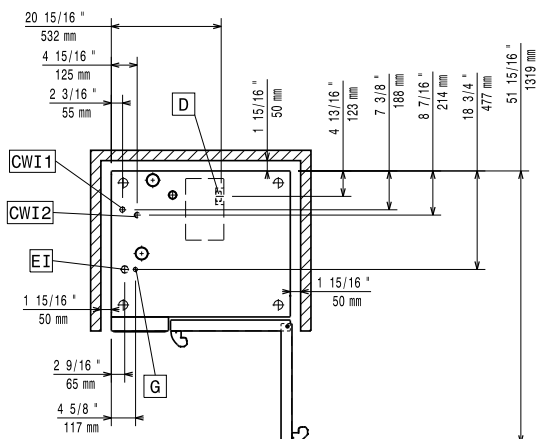

### Electric

#### Supply voltage:

227680 (ECOG61K2GB) 220-240 V/1 ph/50 Hz

#### Electrical power, default:

1.1 kW

Default power corresponds to factory test conditions.

When supply voltage is declared as a range the test is performed at the average value. According to the country, the installed power may vary within the range.

#### Electrical power max.:

1.1 kW

#### Circuit breaker required

### Gas

#### Gas Power:

12 kW

#### Standard gas delivery:

Natural Gas G20

#### ISO 7/1 gas connection diameter:

1/2" MNPT

#### Total thermal load:

40908 BTU (12 kW)

### Water:

#### Water inlet connections "CWI1-CWI2":

3/4"

#### Pressure, bar min/max:

1-6 bar

#### Drain "D":

50mm

#### Max inlet water supply temperature:

30 °C

#### Hardness:

5 °fH / 2.8 °dH

#### Chlorides:

<10 ppm

#### Conductivity:

0 µS/cm

Electrolux Professional recommends the use of treated water, based on testing of specific water conditions.

Please refer to user manual for detailed water quality information.

### Installation:

#### Clearance:

Clearance: 5 cm rear and right hand sides.

#### Suggested clearance for service access:

50 cm left hand side.

### Capacity:

#### Trays type:

5 - 400x600

#### Max load capacity:

30 kg

### Key Information:

#### Door hinges:

External dimensions, Width: 867 mm

External dimensions, Depth: 775 mm

External dimensions, Height: 808 mm

Net weight: 118 kg

Shipping weight: 135 kg

Shipping volume: 0.89 m<sup>3</sup>

### ISO Certificates

#### ISO Standards:

ISO 9001; ISO 14001; ISO 45001; ISO 50001